

***Rotabroach***<sup>TM</sup>  
***COMMANDO 40***  
Magnetic drilling machine

Model Number COMMANDO40/1, COMMANDO40/3

This machine is CE approved.

**Rotabroach<sup>TM</sup> Ltd**

Imperial Works, Sheffield Road  
Sheffield, South Yorkshire  
United Kingdom  
S9 2YL

Tel: +44 (0) 114 2212 510 Fax: +44 (0) 114 2212 563  
Email: sales@rotabroach.co.uk Web site: www.rotabroach.co.uk

**Thank you for purchasing our Commando 40 magnetic drill.  
We would really like your feedback on the machine.**

***Other Products by Rotabroach™:***



**Thank you for your purchase of our product.**

For more information please visit our website at [www.rotabroach.co.uk](http://www.rotabroach.co.uk)

Or contact our sales department on +44 (0) 114 2212 510

## CONTENTS OF THE MANUAL.

|  |    |
|--|----|
| 1) INTENDED USE                        | 4  |
| 2) GENERAL SAFETY RULES                | 4  |
| 3) OPERATIONAL SAFETY PROCEDURES       | 4  |
| 4) INFORMATION PLATE SYMBOLS           | 6  |
| 5) SPECIFICATION                       | 7  |
| 6) MAGNET DETECTION                    | 8  |
| 7) EXTENSION CABLE SELECTION           | 9  |
| 8) MOUNTING OF CUTTERS                 | 9  |
| 9) REMEDIES FOR HOLE MAKING PROBLEMS   | 10 |
| 10) WIRING DIAGRAM                     | 11 |
| 11) EXPLODED VIEW OF MACHINE           | 12 |
| 12) EXPLODED VIEW OF MOTOR AND GEARBOX | 13 |
| 13) PARTS LIST                         | 14 |
| 14) PIPE ADAPTOR KIT RD2311            | 15 |
| 15) FITTING THE CHUCK                  | 16 |
| 16) MAINTENANCE                        | 16 |
| 17) TROUBLE SHOOTING                   | 18 |
| 18) CUTTER SELECTION AND SPEEDS        | 20 |
| 19) WARRANTY STATEMENT                 | 22 |

| P/N     | Drawing number | List of Contents with Magnetic Drill Unit | Check list (Y/N) |
|---------|----------------|---|------------------|
| RD4329  | 64             | Safety Strip                              |                  |
| RD43207 | 65             | Hexagon Spanner 4mm                       |                  |
| RD4152  | 66             | Hexagon Spanner 3mm                       |                  |
| RD33154 | 67             | Drill Chuck Key                           |                  |
| RD43099 | 68             | 13mm Drill Chuck                          |                  |
| RD33153 | 69             | Drill Chuck Adaptor                       |                  |
| RD35612 | 8.35           | Replacement Carbon Brush                  |                  |

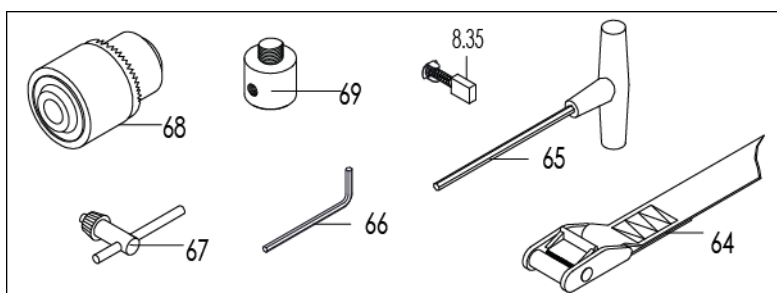

## 1) INTENDED USE

The intended use of this magnetic drill, is to drill holes in ferrous metals. The magnet is used to hold the drill in place whilst the drill is functioning.

Any deviation from its intended use will not be covered by warranty.

## 2) GENERAL SAFETY RULES

Read all these instructions before attempting to operate the machine.

**WARNING!** When using electric tools basic safety precautions should always be followed to reduce the risk of fire, electric shock and personal injury, including the following.

Remove the power supply before carrying out any adjustment, servicing or maintenance.

Follow instructions for lubricating and changing accessories.

All repairs to be carried out by an authorized Rotabroach service facility.

## 3) OPERATIONAL SAFETY PROCEDURES

### OPERATING INSTRUCTIONS

#### READ BEFORE USING THE MACHINE

1. BEFORE operating, the machine MUST be securely restrained to a fixed independent feature (by using safety strap RD4329, or other means), to reduce the potential free movement should the magnet become detached from the work piece. Failure to do so may result in personal injury.
2. Keep other persons away. DO NOT let untrained persons, especially children, touch the tool or the extension cord and keep them away from the work area.
3. Avoid unintentional starting. Ensure the magnet is OFF before plugging the machine in.
4. Consider the toxicity of dust produced from the cutter and material being cut. Use approved extraction and or Personal Protective Equipment (PPE).
5. Secure work where possible, use clamps or a vice to hold the work. It is safer than using your hand.
6. Form the habit of checking to see that keys and adjusting wrenches are removed from the tool before turning it on.
7. Never operate the machine if parts are missing or damaged.
8. Never direct jets of water or flammable liquids over the drill.
9. Operator must be physically able to handle the weight of the machine.
10. Operator should be trained in the use of the machine.
11. If the machine is accidentally dropped, ALWAYS thoroughly examine the machine for signs of damage and check that it functions correctly BEFORE resuming drilling.
12. ALWAYS ensure when using the machine in an inverted position that only the minimum amount of coolant is used and that care is taken to ensure that coolant does not enter the motor unit.
13. Keep work area clear - cluttered areas and benches invite injuries.
14. Consider work area environment;
  - Do not expose tools to rain.

- Do not use tools in damp or wet locations.
  - Keep work area well lit (500 Lux recommended).
  - Do not use tools in the presence of flammable liquid or gases
  - Ensure there is adequate space to gain access to the plug, mains and motor on/off switches.
  - Regularly clear the work area and machine of swarf and dirt, paying particular attention to the underside of the magnet base.
15. Do not force the machine. It will do the job better and safer at the rate for which it was intended.
16. Use the right tool;
- Do not force small tools to do the job of a heavy duty tool.
17. When using the drill, always ensure a safe operating distance from any swarf and do not reach into the cutting area, or near the cutter, when the machine is running.
18. Do not overreach! Keep proper footing and balance at all times.
19. Cutting tools may shatter, ALWAYS position the guard over the cutter before activating the machine. Failure to do so may result in personal injury.
20. Apply light pressure when commencing to cut a hole until the cutter is introduced into the work surface. Pressure can then be increased sufficiently to load the motor. Excessive pressure is undesirable, it does not increase the speed.
21. Use Personal Protective Equipment (PPE) when using this machine;
- Use safety glasses to prevent debris from damaging eyes.
  - Use ear defenders or ear plugs for hearing protection.
  - Use face or dust masks if cutting operations create dust.
  - Use protective gloves to prevent swarf or debris cutting the skin.
22. Dress properly;
- Do not wear loose clothing or jewellery; they can be caught in moving parts.
  - Non-skid footwear is recommended when working outdoors.
  - Wear a protective hair covering to contain long hair. This will reduce the risk of entanglement.
23. Maintain tools with care;
- Keep cutting tools sharp and clean for better and safer performance.
  - Regularly check the machine for any wear or damage.
  - Ensure the machine is clean and free from debris prior to use.
  - Remove from the mains prior to any maintenance.
  - Follow instructions for lubricating and changing accessories.
24. On completion of the cut, a slug will be ejected. DO NOT operate the machine if the slug has not ejected as it may cause injury.
25. If the slug sticks in the cutter, move the machine to a flat surface, switch on the magnet and gently bring the cutter down to make contact with the surface. This will usually straighten a cocked slug and allow it to eject normally.
26. Store idle tools when not in use. All tools should be stored in a dry locked-up place, out of reach of children
27. WARNING! The vibration emissions during actual use can differ from the declared total value depending on the ways in which the tool is being used.

28. Stay alert! Watch what you are doing, use common sense and do not operate the tool when you are tired. DO NOT operate the machine when under the influence of alcohol or ANY illegal substances.
29. Warning! The use of any accessory or attachment, other than ones recommended in this instruction manual, may present a risk of personal injury.
30. Insecure anchorage, a loosely fitting slide or a worn bearing in the arbor support usually causes cutter breakage.
31. Guard against electric shock: Avoid body contact with earthed or ground surfaces (e.g. pipes, radiators, cookers and refrigerators).
32. Electric safety can be further improved by using a high-sensitivity (30 m A/0.1s) residual current device (RCD).
33. Do not abuse the cord; never pull the cord to disconnect it from the socket. Keep the cord away from heat, oil and sharp edges.
34. Inspect tool cords periodically and if damaged have it repaired by an authorized Rotabroach service facility.
35. Only use extension cables approved for site conditions.

#### 4) INFORMATION PLATE SYMBOLS

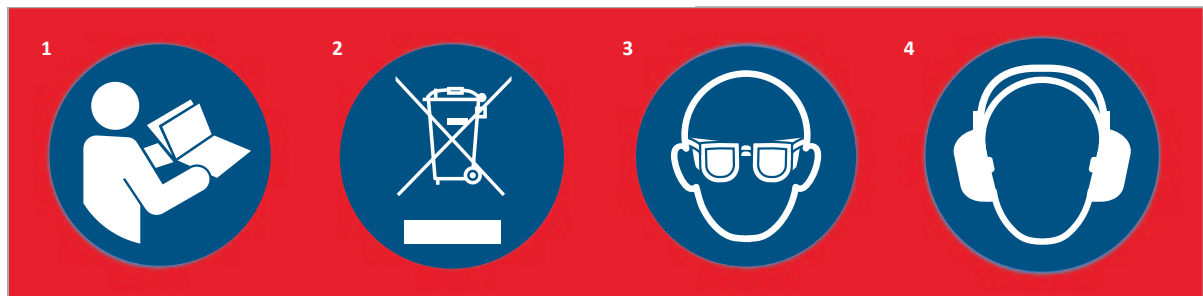

- 1 Refer to the user manual for operational and safety issues with regard to this machine.
- 2 Dispose of the machine and electrical components correctly.
- 3 Eye protection must be worn when operating the machine.
- 4 Ear defenders must be worn when operating the machine.

## 5) SPECIFICATION

Maximum hole cutting capacity in .2/.3C steel = 40mm dia. x 50mm deep

Arbor bore = 19.05mm (3/4") dia.

|   |                                  |              |  |
|---|----------------------------------|--------------|--|
| <b>Motor Unit</b><br>(Nominal values)   | COMMANDO40/1                     | 110V 50-60Hz | 1100W (10A)  |
|   | COMMANDO40/3                     | 230V 50-60Hz | 1100W  |
| Electro Magnet  | COMMANDO40/1                     | 110V 50-60Hz | 45W  |
|   | COMMANDO40/3                     | 230V 50-60Hz | 45W  |
| Total Normal Full Load (magnet + motor)   |                                  |              | 1145W  |
| Overall Dimensions  | Height (maximum extended)        |              | 510 mm   |
|   | Width (including Hand Wheel)     |              | 180 mm   |
|   | Length Overall (including Guard) |              | 265 mm   |
|   | Magnet Footprint                 |              | 165mm x 80mm   |
| Nett Weight   |                                  |              | 14.6 kg  |
| Stroke  |                                  |              | 85mm   |
| No Load speed   | All voltages                     |              | 270-610 rpm  |
| Tractive Force of Magnet at 20° C (25mm min. plate thickness)<br><b>The use on any material less than 25mm thick will progressively reduce the magnetic performance. If possible substitute material should be positioned under the magnet and work piece to equate to a suitable material thickness. If this is not possible an alternative secure method of restraining the machine MUST be used. Failure to do so may result in personal injury.</b> |                                  |              | 8000N  |
| Maximum hand/arm vibration magnitude (measured at handle during operation in accordance with ISO5349, using a 22mm dia cutter through a 13mm mild steel plate).   |                                  |              | 2.892 m/s <sup>2</sup>   |
| Estimate of vibration exposure. Operation 30 holes @ 1 minute/hole.   |                                  |              | 0.13 m/s <sup>2</sup> A(8)   |
| Average noise level during cutting at operator's ear position.  |                                  |              | L <sub>PA</sub> Max. 88.4 dB(A)<br>L <sub>WA</sub> Max. 101.4dB(A) |

Ear and eye defenders must be worn when operating this machine. Wear gloves to protect hands when operating the machine.

These tools are UK designed and manufactured with globally sourced components and conform with the requirements of EEC Document HD.400.1 and BS.2769/84

Suitable only for a single phase 50-60Hz A.C. power supply

### DO NOT USE ON D.C. SUPPLY

Do not use your magnetic drill on the same structure when arc welding is in progress.  
D.C. current will earth back through the magnet and cause irreparable damage.

### **WARNING: THIS APPLIANCE MUST BE EARTHED!**

**NB: ANY MODIFICATIONS TO THIS MACHINE WILL INVALIDATE THE GUARANTEE**

## 6) MAGNET DETECTION

It is advised that when working on thin material a packing piece should be used to increase the material thickness under the magnet. Working on thin material without a packing piece will reduce the magnet holding force.

It is advised that the drill is to be operated on ferrous material 6mm thick and above. Damage to the magnet base, such as pitting, will affect the strength of the magnet holding force.

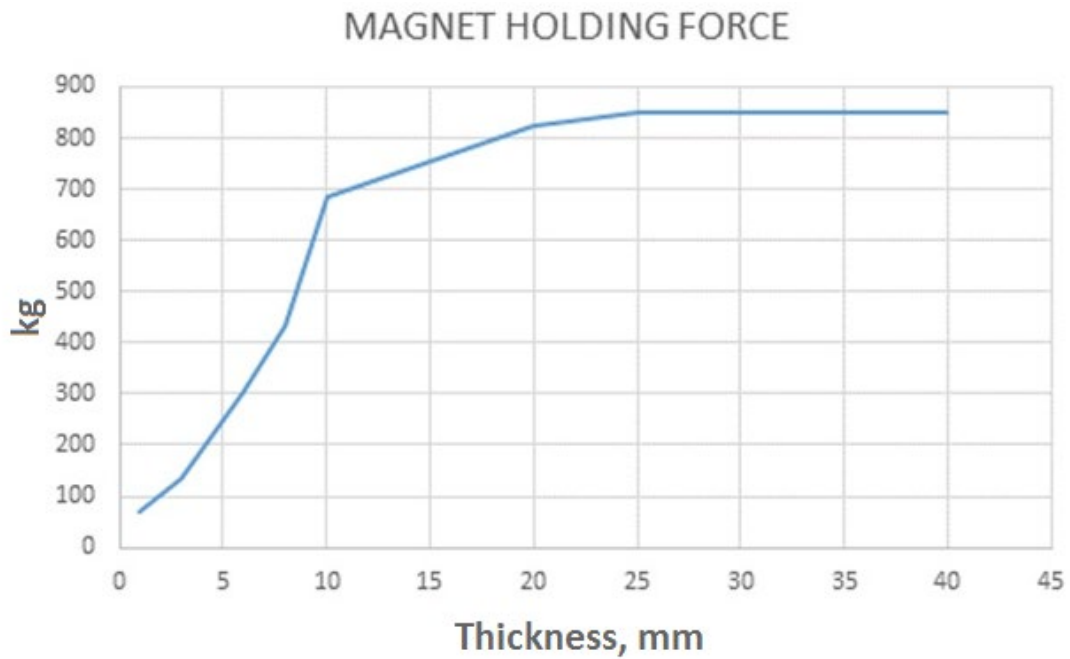



## 7) EXTENSION CABLE SELECTION

The machines are factory fitted with a 3 meter length cable, having three conductors 1.5mm<sup>2</sup> LIVE, NEUTRAL and EARTH. If it becomes necessary to fit an extension cable from the power source, care must be taken in using a cable of adequate capacity. Failure to do so will result in a loss of traction by the magnet and a reduction of power from the motor.

Assuming a normal AC supply of the correct voltage, it is recommended that the following extension lengths shall not be exceeded:

**For 110v supply: 3.5metres of 3 core x 1.5mm<sup>2</sup>**

**For 230v supply: 26metres of 3 core x 1.5mm<sup>2</sup>**

**ALWAYS DISCONNECT THE MACHINE FROM THE POWER SOURCE BEFORE CHANGING CUTTERS.**

## 8) MOUNTING OF CUTTERS

- The machine has been made to accept cutters having 19.05mm (3/4") dia. Weldon shanks. The following procedure is to be used when mounting cutters:
  - Lay the machine on its side with feed handles uppermost, ensuring arbor is wound down to its lowest point to enable access to socket screws RD4066.
  - Take appropriate pilot and place through the hole in the cutter shank. Insert shank of cutter into bore of arbor, ensuring alignment of two drive flats with socket screws.
  - Tighten both screws using hexagon key.

## 9) REMEDIES FOR HOLE MAKING PROBLEMS

| <i>Problem</i>  | <i>Cause</i>  | <i>Remedy</i>   |
|---|---|---|
| 1) Magnetic base won't hold effectively                       | Material being cut may be too thin for efficient holding.                                     | Attach an additional piece of metal under work-piece where magnet will be located, or mechanically clamp magnetic base to work-piece.   |
|   | Swarf or dirt under magnet.   | Clean magnet.   |
|   | Irregularity on magnet contact or work-piece.   | Use extreme care; file any imperfections flush to surface.  |
|   | Insufficient current going to magnet during drilling cycles.                                  | Confirm power supply and output from control unit, check supply cable.  |
| 2) Cutter skips out of centre-punch mark at initiation of cut | Magnetic base is not holding effectively.   | See causes and remedies above.  |
|   | Worn arbor bushing and/or ejector collar.   | Replace! Only a few thousandths wear permissible. New arbor bushing is needed. Light pressure only is needed until a groove is cut. The groove then serves as a stabiliser.   |
|   | Too much feed pressure at start of cut.   | Replace or re-sharpen. Sharpening service is available.   |
|   | Cutter is dull, worn, chipped or incorrectly sharpened.                                       | Improve centre-punch and/or replace worn parts  |
|   | Poor centre-punch mark; weak pilot spring; pilot not centred in centre-punch mark.            | Replace part or parts   |
|   | Worn or bent pilot, worn pilot hole.  | Replace part or parts   |
|   | Loose bolts on motor bushing support bracket, main casting or loose gib adjusting set screws. | Adjust where necessary  |
| 3) Excessive drilling pressure required                       | Incorrectly re-sharpened, worn or chipped cutter.   | Re-sharpen or replace.  |
|   | Coming down on swarf lying on surface of work-piece.  | Take care not to start a cut on swarf.  |
|   | Gibs out of adjustment or lack of lubrication.  | Adjust setscrews, and lubricate.  |
|   | Swarf accumulated (packed) inside cutter.   | Clear cutter.   |
| 4) Cutter breakage  | Steel swarf or dirt under cutter.   | Remove cutter, clean part thoroughly and replace.   |
|   | Incorrectly re-sharpened or worn cutter.  | Always have a new cutter on hand to refer to for correct tooth geometry, together with instruction sheet.   |
|   | Cutter skipping.  | See causes and remedies (2).  |
|   | Gib Strip need adjustment.  | Tighten Gib Strip.  |
|   | Cutter not attached tightly to arbor.   | Retighten.  |
|   | Insufficient use of cutting oil or unsuitable type of oil.                                    | Inject oil of light viscosity into the coolant-inducing ring and check that oil is being metered into cutter when pilot is depressed. If not, check pilot groove and arbor internally for dirt or apply oil externally. (Even a small amount of oil is very effective). |
| 5) Excessive cutter wear                                      | See cause and remedy above  |   |
|   | Incorrectly re-sharpened cutter.  | Do not use. Refer to instructions and a new cutter for proper tooth geometry.   |
|   | Exercise, insufficient or spasmodic cutting pressure.   | Use sufficient steady pressure to slow the drill down. This will result in optimum cutting speed and chip load.   |

**10) WIRING DIAGRAM**

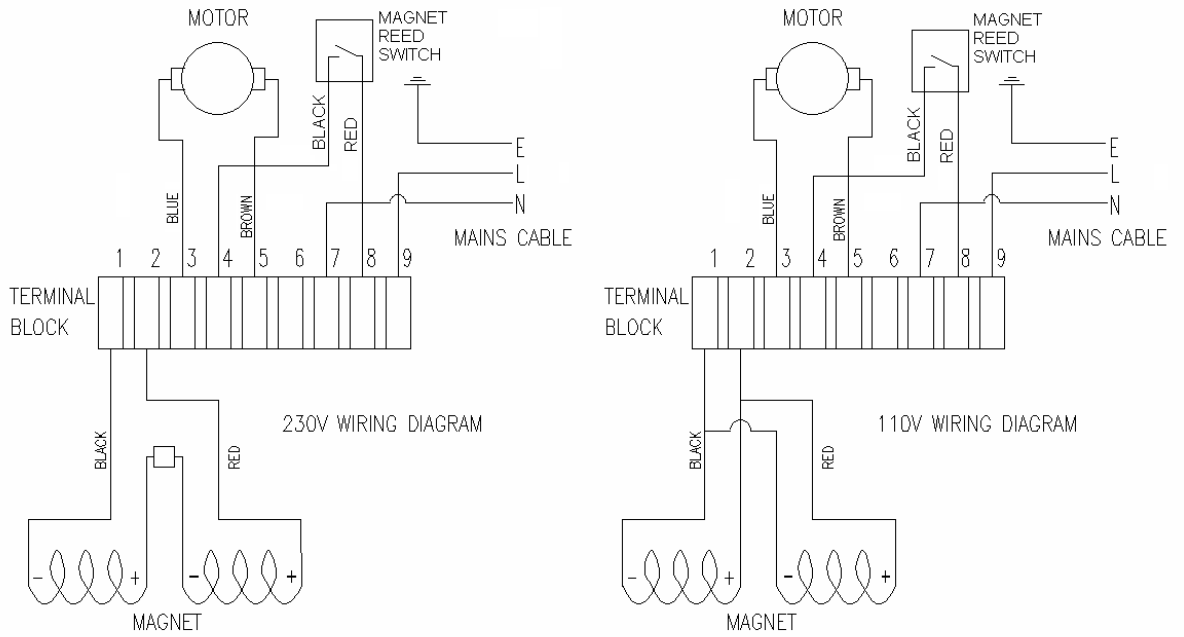

11) EXPLODED VIEW OF MACHINE

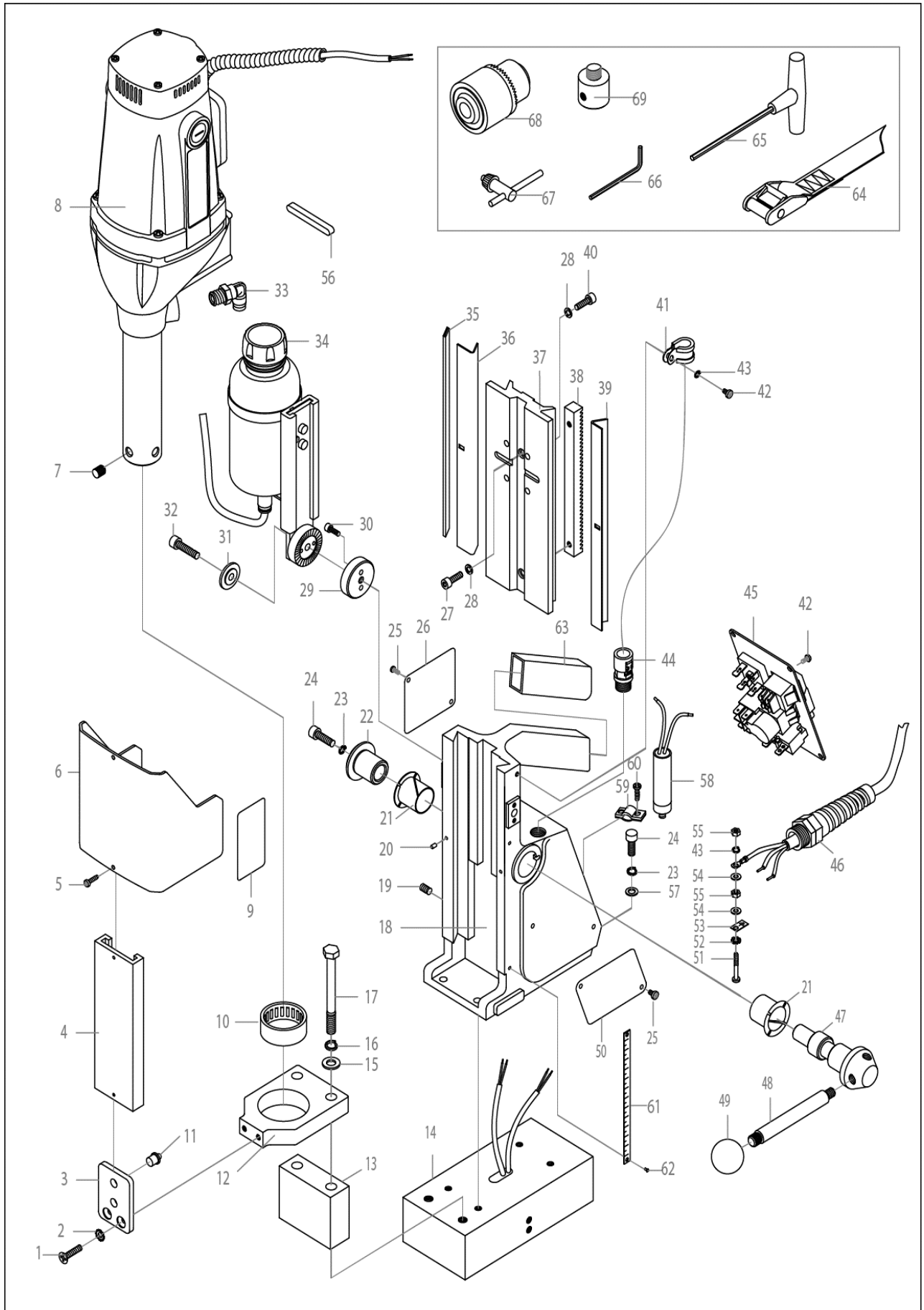

**12) EXPLODED VIEW OF MOTOR AND GEARBOX**

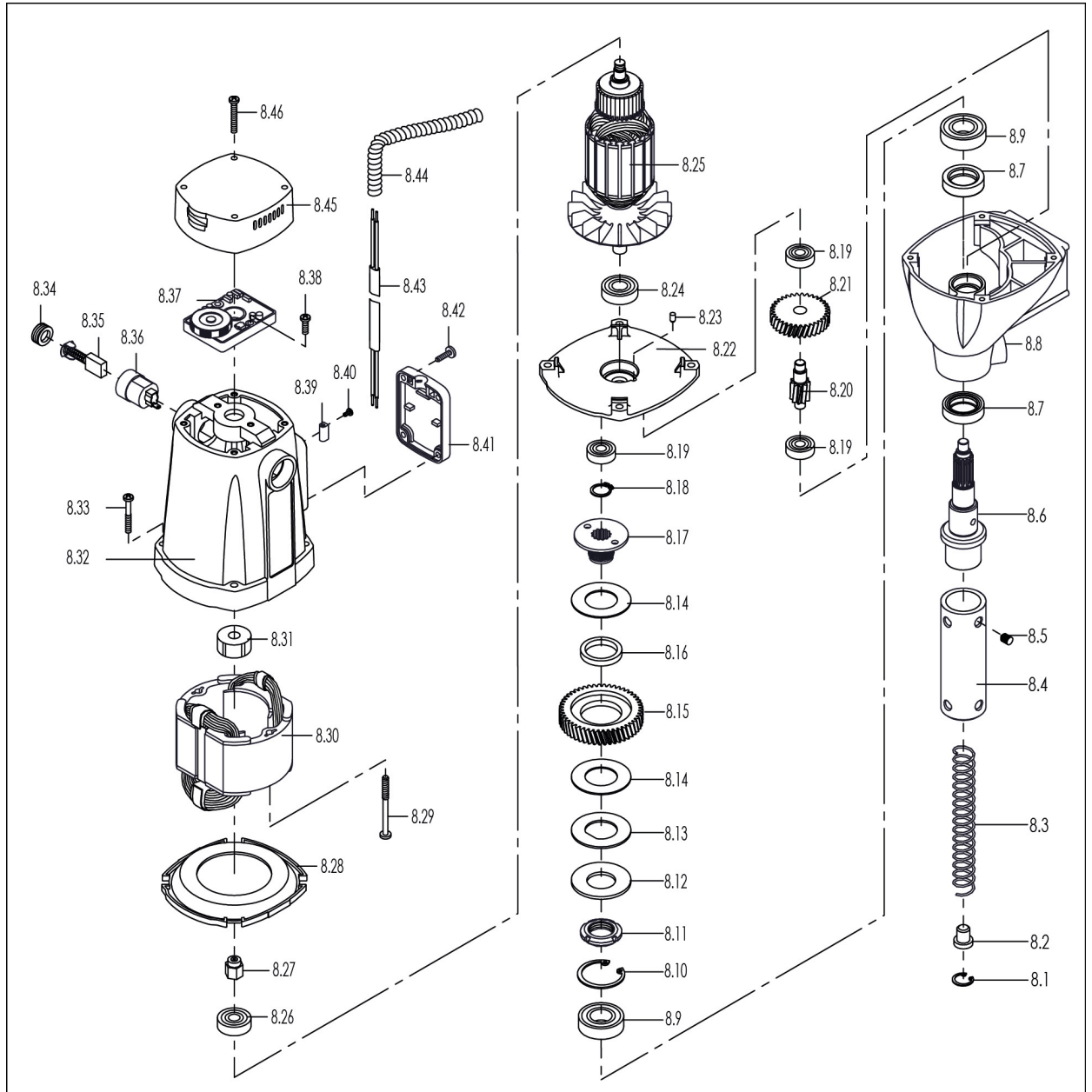

### 13) PARTS LIST

| Item | Rotabroach P/N    | Description                 | Qty/pcs |
|------|-------------------|-----------------------------|---------|
| 1    | RD4347            | M5x16 Cross Sunk Screw      | 2       |
| 2    | RD45607           | M5 Lock Washer              | 2       |
| 3    | RD33344           | Guard Support               | 1       |
| 4    | RDA3031           | Side Channel                | 1       |
| 5    | RD4201            | Screw M4x14 BTTN HD         | 2       |
| 6    | RD33345           | Guard                       | 1       |
| 7    | RD4066            | M8x8 Lock Screw             | 2       |
| 8    | RD236114/RD23115  | Motor Assembly 110V/230V    | 1       |
| 8.1  | RD4056            | Circlip 19-Hole             | 1       |
| 8.2  | RA354             | Button                      | 1       |
| 8.3  | RA3118            | Spring                      | 1       |
| 8.4  | RD33155           | Arbor                       | 1       |
| 8.5  | RD4066            | Screw M8x8                  | 2       |
| 8.6  | RD33156           | Arbor Spindle               | 1       |
| 8.7  | RD43304           | Oil Seal                    | 2       |
| 8.8  | RD33602           | Gearbox                     | 1       |
| 8.9  | RD43305           | Ball Bearing 6003           | 2       |
| 8.10 | RD43306           | Circlip 35-Hole             | 1       |
| 8.11 | RD43607           | Lock Assembly               | 1       |
| 8.12 | RD43626           | Dishing Washer              | 1       |
| 8.13 | RD43608           | Washer                      | 1       |
| 8.14 | RD33603           | Brass Washer                | 2       |
| 8.15 | RD33604           | Big Gear                    | 1       |
| 8.16 | RD43609           | Gear Bushing                | 1       |
| 8.17 | RD33606           | Internal Tooth Bushing      | 1       |
| 8.18 | RD43310           | Circlip 14-Shaft            | 1       |
| 8.19 | RM17134           | Ball Bearing 608            | 3       |
| 8.20 | RD33607           | Gear-Shaft                  | 1       |
| 8.21 | RD33608           | Small Gear                  | 1       |
| 8.22 | RD33609           | Inner Gearplate             | 1       |
| 8.23 | RD45614           | Bearing Pin                 | 1       |
| 8.24 | RD45522           | Ball Bearing 6001           | 1       |
| 8.25 | RD33610/RD33623   | Armature 110V/230V          | 1       |
| 8.26 | RD43603           | Ball Bearing 629            | 1       |
| 8.27 | RD35639           | Inductor                    | 1       |
| 8.28 | RD33611           | Fan Baffle                  | 1       |
| 8.29 | RD43625           | Tapping Screw St4.8x65      | 2       |
| 8.30 | RD33633 / RD33631 | Field Leadwire Sa 230v/110v | 1       |
| 8.31 | RDB3069           | Bearing Sleeve              | 1       |
| 8.32 | RD33186           | Motor Frame                 | 1       |
| 8.33 | RD43624           | Screw SA M5x42              | 4       |
| 8.34 | RD33616           | Brush Cover                 | 2       |
| 8.35 | RD35612           | Brush                       | 2       |
| 8.36 | RD33614           | Brush Holder                | 2       |
| 8.37 | RD23630/RD23643   | Speed Controller 110V/230V  | 1       |
| 8.38 | RD45610           | Tapping Screw St3.9x16      | 2       |
| 8.39 | RD35617           | Terminal                    | 2       |
| 8.40 | RD45613           | Screw M3x6                  | 4       |
| 8.41 | RD35619           | Protector                   | 1       |
| 8.42 | RD45612           | Tapping Screw St4.2x12      | 4       |
| 8.43 | RD23623           | Motor Cable Assembly        | 1       |
| 8.45 | RD35615           | End Cap                     | 1       |
| 8.46 | RD43618           | Tapping Screw St3.9x32      | 4       |
| 9    | RD33070           | Information Plate           | 1       |
| 10   | RD45624           | Needle Bearing Hk354216     | 1       |
| 11   | RD45620           | Ball                        | 2       |
| 12   | RD33635           | Bearing Bracket             | 1       |

| Item | Rotabroach P/N  | Description                | Qty/pcs |
|------|-----------------|----------------------------|---------|
| 13   | RD33148         | Spacer For Bearing Bracket | 1       |
| 14   | RD23625/RD23626 | Magnet Assembly 110V/ 230V | 1       |
| 15   | RD4078          | M8 Flat Washer             | 2       |
| 16   | RD4079          | M8 Elastic Washer          | 2       |
| 17   | RD43619         | M8x88 Hex Head Tap Bolt    | 2       |
| 18   | RD33632         | Housing Assembly           | 1       |
| 19   | RD4312          | M6x12 Lock Screw           | 4       |
| 20   | RD45622         | Pin 3x8                    | 2       |
| 21   | RD4313          | Sleeve                     | 2       |
| 22   | RD3303          | Pinion Shaft Sleeve        | 1       |
| 23   | RD4096          | M6 Elastic Washer          | 5       |
| 24   | RD4098          | M6x20 Socket Cap Screw     | 5       |
| 25   | RD4077          | M4x6 Cross Panhead Screw   | 4       |
| 26   | RD4302          | Warning Label              | 1       |
| 27   | RD4325          | M5x16 Socket Cap Screw     | 2       |
| 28   | RD4092          | M5 Elastic Washer          | 6       |
| 29   | RD33338         | Dirigible Wheel            | 1       |
| 30   | RD4414          | M4x10 Socket Cap Screw     | 2       |
| 31   | RD33320         | Clamp Assembly             | 1       |
| 32   | RD4269          | M6x25 Socket Cap Screw     | 1       |
| 33   | RD45605         | Infall Connector           | 1       |
| 34   | RD23603         | Cooling Bottle Assembly    | 1       |
| 35   | RD33644         | Gib Support Strip          | 1       |
| 36   | RD33645         | Adjustable Gib Strip       | 1       |
| 37   | RD33630         | Slide                      | 1       |
| 38   | RD33600         | Rack                       | 1       |
| 39   | RD33646         | Fixed Gib Strip            | 1       |
| 40   | RD4091          | M5x25 Socket Cap Screw     | 4       |
| 41   | RD4210          | Coil Pipe Clamp            | 1       |
| 42   | RD4077          | M4x8 Cross panhead Screw   | 5       |
| 43   | RD43357         | M4 Elastic Washer          | 2       |
| 44   | RD43600         | Connector                  | 1       |
| 45   | RD23109/RD23110 | Control Panel 110V/230V    | 1       |
| 46   | RD25619/RD25620 | Cable Assembly 110V/230v   | 1       |
| 47   | RD33643         | Capstan Spindle            | 1       |
| 48   | RD33642         | Capstan Arm                | 3       |
| 49   | RD43091         | Capstan Ball               | 3       |
| 50   | RD33178         | Brand Label                | 1       |
| 51   | RD45621         | M4x22 Cross Panhead Screw  | 1       |
| 52   | RD4069          | M4 External Tooth Washer   | 1       |
| 53   | RD45604         | Earth Tag                  | 1       |
| 54   | RD4070          | M4 Flat Washer             | 2       |
| 55   | RD4068          | M4 Hexagon Nut             | 2       |
| 56   | RD33341         | Flat Key                   | 1       |
| 57   | RD4095          | M6 Flat Washer             | 4       |
| 58   | RD45606         | Protecting Switch          | 1       |
| 59   | RD43117         | Cable Gland                | 1       |
| 60   | RD43093         | M4x14 Cross Panhead Screw  | 2       |
| 61   | RD33145         | Depth Gauge                | 1       |
| 62   | RD33146         | Label-Plate Rivet          | 2       |
| 63   | RD33144         | Handle Sheath              | 1       |
| 64   | RD4329          | Safety Strip               | 1       |
| 65   | RD43207         | Hexagon Spanner 4mm        | 1       |
| 66   | RD4152          | Hexagon Spanner 3mm        | 1       |
| 67   | RD33154         | Drill Chuck Key            | 1       |
| 68   | RD43099         | 13mm Drill Chuck           | 1       |
| 69   | RD33153         | Drill Chuck Adaptor        | 1       |

**14) PIPE ADAPTOR KIT RD2311****FITTING INSTRUCTIONS**

- Dependent upon the size of the pipe to be cut (see illustrations) attach adjustable angle plates RD3328 with cap screws RD4325 and washers RD4205 (4 off each) to the magnet sides. Do not tighten.
- Locate the machine on the centreline of the pipe taking care that the magnet is in line with the longitudinal axis of the pipe.
- Switch on the magnet and move the sliding plates down to the outside diameter of the pipe. Tighten the screws on both sides by hand then check once again that the full length of the moving plates is touching the pipe at the front and back, fasten the plate securely. Feed the safety strap through the lugs at the front of the housing, around the pipe and pull tight.
- When cutting the hole DO NOT use excessive pressure but rather let the cutter ease into the cutting surface.

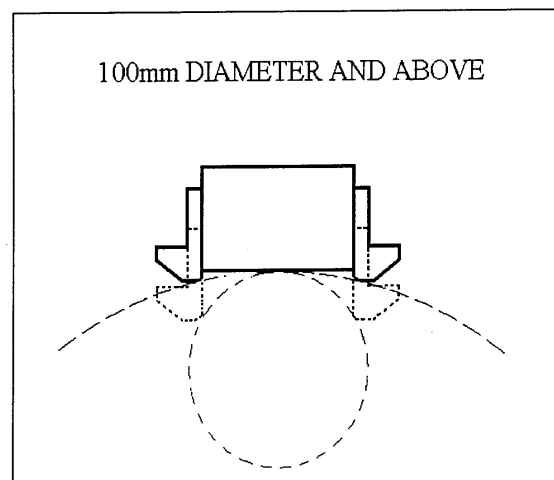
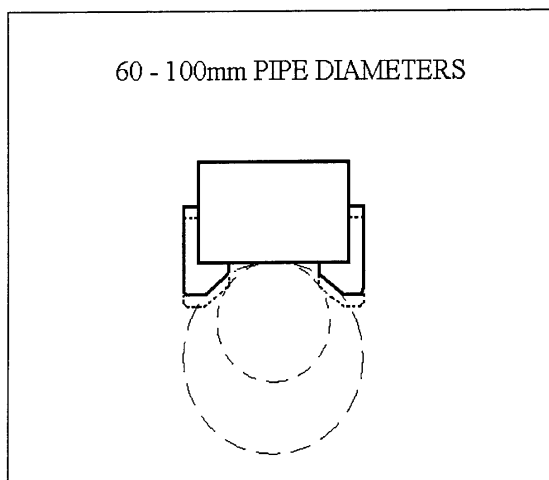

## 15) FITTING THE CHUCK

- To remove the arbor lay the machine on its side.
- Unscrew the two grub screws at the top of the arbor.
- When the arbor has become detached from the spindle this can then be removed.
- Remove the arbor support bracket and guard with the arbor retained.
- Mount the chuck using the chuck adaptor RD33153.
- Replacing the chuck is the reverse sequence.

## 16) MAINTENANCE

In order to 'get the best life' out of your Rotabroach machine always keep it in good working order. A number of items must always be checked on Rotabroach machines. Always before starting any job make sure the machine is in good working order and that there are no damaged or loose parts. Any loose parts must be tightened.

**Before proceeding with any maintenance work be certain that the power supply is disconnected.**

| Description                        | Every operation | 1 week | 1 Month |
|------------------------------------|-----------------|--------|---------|
| Visual check of machine for damage | X               |        |         |
| Operation of machine               | X               |        |         |
| Check brush wear                   |                 | X      |         |
| Check magnetic base                | X               |        |         |
| Check alignment of the machine     |                 |        | X       |
| Check grease                       |                 |        | X       |
| Check armature                     |                 |        | X       |

### Visually check the machine for damage.

The machine must be checked before operation for any signs of damage that will affect the operation of the machine. Particular notice must be taken to the mains cable, if the machine appears to be damaged it should not be used, failure to do so may cause injury or death.

### Check operation of the machine.

The machines operation must be checked to ensure that all components are working correctly.

**Machine Brushes** - should be checked to make sure there is no abnormal wear present (this should be checked at least once a week if used frequently). If the brush has worn more than  $\frac{1}{3}$  the original length, the brushes should be changed. Failure to do so may cause damage to the machine.

**Magnetic base** – before every operation the magnetic base should be checked to make sure that the base is flat and there is no damage present. An uneven magnet base will cause the magnet not to hold as efficiently and may cause injury to the operator.

### Adjustment of slide and bearing bracket alignment.

An essential requirement of the machine is that the slide can move in a smooth and controlled manner, free of lateral movement and vibration.

This situation can be maintained by periodic adjustment of the slide and is accomplished in the following manner:



1. Place the machine in an upright position and, by means of the capstan, raise the slide to its highest position. Clean the brass Gib Strips and apply a small amount of light machine oil to the wear surfaces.
2. Now lower the slide back to its lowest position. Bring the slide into the center of the dovetail slide housing and loosen screws thus allowing free movement of the arbor support bracket.
3. Commencing with the middle screws, gently feed in all the screws until slight resistance is encountered.
4. Operate the slide up and down a few times to test the movement and make any further necessary adjustments. Try to ensure that all the screws are exerting a uniform pressure on the slide from top to bottom. A perfectly adjusted slide will operate freely up and down without any sideways movement.
5. Now raise the slide to its highest position. Slightly undo the arbor bearing bracket and, using fingers only, tighten the screws.
6. Place the machine on a steel plate, connect to power supply and switch on the magnet. Start up the motor. If the arbor is incorrectly aligned, the arbor support bracket will be seen to oscillate. Make any necessary further adjustments to the bracket to ensure correct alignment of the spindle and finally tighten the screws using a spanner. Lastly tighten the arbor bearing bracket.

**Check machines grease.**

The gearbox grease should be checked once a month to ensure all moving components are covered to prevent wear. The grease should be changed at least once a year to ensure you gain the best from your machine.

**Check Armature of the machine.**

This should be checked at least once a month to check that there are no visual signs of damage to the body or to the commutator. Some signs of wear will be seen on the commutator over a period of time but this is normal (this is the part that comes into contact with the brushes) however, if there are any signs of abnormal damage the part should be replaced.

## 17) TROUBLE SHOOTING

|   |   |
|---|---|
| Magnet and motor do not function                                  | <ul style="list-style-type: none"> <li>- The magnet switch is not connected to the power supply</li> <li>- Damaged or defective wiring</li> <li>- Defective fuse</li> <li>- Defective magnet switch</li> <li>- Defective control unit</li> <li>- Defective power supply</li> </ul>  |
| Magnet does function, the motor does not                          | <ul style="list-style-type: none"> <li>- Damaged or defective wiring</li> <li>- Carbon brushes are stuck or worn out</li> <li>- Defective magnet switch</li> <li>- Defective on / off switch</li> <li>- Defective Control Unit</li> <li>- Defective armature and/or field</li> <li>- Defective magnet protective switch</li> </ul>                          |
| Magnet does not function, the motor does                          | <ul style="list-style-type: none"> <li>- Defective magnet</li> <li>- Defective control unit</li> </ul>  |
| Hole cutters break quickly, holes are bigger than the hole cutter | <ul style="list-style-type: none"> <li>- Play in the guide</li> <li>- Bent spindle</li> <li>- Defective magnet causing movement</li> <li>- Shaft extending from the motor is bent</li> <li>- Uneven work surface causing lack of magnetic adhesion.</li> <li>- Bent pilot</li> </ul>  |
| Motor running roughly and/or seizing up                           | <ul style="list-style-type: none"> <li>- Bent spindle</li> <li>- Shaft extending from the motor is bent</li> <li>- Triangular guide not mounted straight</li> <li>- Dirt between spindle and triangular guide</li> </ul>  |
| Motor making a rattling sound                                     | <ul style="list-style-type: none"> <li>- Gear bearing (bottom of the armature) worn out</li> <li>- Gear(s) worn out</li> <li>- No grease in gear box</li> </ul>   |
| Motor humming, big sparks and motor has no force                  | <ul style="list-style-type: none"> <li>- Armature burned</li> <li>- Field burned</li> <li>- Carbon brushes worn out</li> </ul>  |
| Motor does not start or fails.                                    | <ul style="list-style-type: none"> <li>- Damaged or defective wiring</li> <li>- Dirt in sensor of speed control unit</li> <li>- Defective speed control unit</li> <li>- Defective speed control or its wiring</li> <li>- Defective or loose magnet on top of armature</li> <li>- Damaged or defective brushes</li> </ul>                                    |
| Guiding takes a great deal of effort                              | <ul style="list-style-type: none"> <li>- Guide is set too tight</li> <li>- Guide is dry</li> <li>- Guide/gear- rack/rotation system dirty or damaged</li> </ul>   |
| Insufficient magnetic force                                       | <ul style="list-style-type: none"> <li>- Damaged or defective wiring</li> <li>- Bottom of magnet not clean and dry</li> <li>- Bottom of magnet not flat</li> <li>- Work piece is not bare metal</li> <li>- Work piece is not flat</li> <li>- Work piece is too thin less than 10mm</li> <li>- Defective control unit</li> <li>- Defective magnet</li> </ul> |
| Motor only runs at maximum rpm                                    | <ul style="list-style-type: none"> <li>- Defective speed switch</li> <li>- Damaged / defective wiring</li> <li>- Defective control unit</li> </ul>  |

|  |   |
|--|---|
| Fuse blows when magnet switch is turned on | <ul style="list-style-type: none"><li>- Damaged or defective wiring</li><li>- Wrong value fuse</li><li>- Defective magnet switch</li><li>- Defective control unit</li><li>- Defective magnet</li></ul>  |
| Fuse blows when motor is started up        | <ul style="list-style-type: none"><li>- Damaged or defective wiring</li><li>- Wrong value fuse</li><li>- Motor running roughly</li><li>- Defective armature and / or field</li><li>- Carbon brushes worn out</li><li>- Defective control unit</li></ul> |
| Rotation system free stroke too long       | <ul style="list-style-type: none"><li>- Loose or defective gear-rack</li><li>- Defective rotation system</li></ul>  |

## 18) CUTTER SELECTION AND SPEEDS

| Material                     | Material Hardness     | Cutter          |
|------------------------------|-----------------------|-----------------|
| Mild and free cutting steels | <700N/mm <sup>2</sup> | RAP or RAPL     |
| Mild and free cutting steels | <850N/mm <sup>2</sup> | SRCV or SRCVL   |
| Steel angle and joists       | <700N/mm <sup>2</sup> | RAP or RAPL     |
| Steel angle and joists       | <850N/mm <sup>2</sup> | SRCV or SRCVL   |
| Plate and sheet steel        | <700N/mm <sup>2</sup> | RAP or RAPL     |
| Plate and sheet steel        | <850N/mm <sup>2</sup> | SRCV or SRCVL   |
| Aluminium                    | <750N/mm <sup>2</sup> | RAP or RAPL     |
| Aluminium                    | <850N/mm <sup>2</sup> | SRCV or SRCVL   |
| Brass                        | <700N/mm <sup>2</sup> | RAP or RAPL     |
| Brass                        | <850N/mm <sup>2</sup> | SRCV or SRCVL   |
| Cast iron                    | <700N/mm <sup>2</sup> | RAP or RAPL     |
| Cast iron                    | <850N/mm <sup>2</sup> | SRCV or SRCVL   |
| Stainless steel              | <700N/mm <sup>2</sup> | RAP or RAPL     |
| Stainless steel              | <850N/mm <sup>2</sup> | SRCV or SRCVL   |
| Stainless steel              | >850N/mm <sup>2</sup> | CWC to CWCX     |
| Rail track                   | >850N/mm <sup>2</sup> | SCRWC or SCRWCL |
| Tool steel                   | >850N/mm <sup>2</sup> | CWC to CWCX     |
| Die Steel                    | >850N/mm <sup>2</sup> | CWC to CWCX     |

Possible speed selection for mild steel with ideal conditions at 30 M/min.

| Speed selector position. | Cutter diameter | Nominal RPM |
|--------------------------|-----------------|-------------|
| <b>1</b>                 | <b>40</b>       | <b>270</b>  |
| <b>2</b>                 | <b>32</b>       | <b>330</b>  |
| <b>3</b>                 | <b>24</b>       | <b>400</b>  |
| <b>4</b>                 | <b>19</b>       | <b>470</b>  |
| <b>5</b>                 | <b>16</b>       | <b>570</b>  |
| <b>6</b>                 | <b>14</b>       | <b>610</b>  |

This data is presented for guidance only, and should be adjusted to suit site and material condition.

The data listed below is for reference purposes only, and indicate potential starting conditions. It is the responsibility of the site operation manager to determine correct application requirements.

| <i>Rotabroach</i> <sup>®</sup> | Cutting surface speed<br>Meters/min | Cutter diameter/Material/RPM relationship |      |      |      |      |      |     |      |     |     |     |     |     |     |
|--------------------------------|-------------------------------------|---|------|------|------|------|------|-----|------|-----|-----|-----|-----|-----|-----|
|                                |                                     | 13  |      | 14   |      | 18   |      | 22  |      | 30  |     | 50  |     | 65  |     |
| Material to be cut             | Lower - Upper                       | L   | U    | L    | U    | L    | U    | L   | U    | L   | U   | L   | U   | L   | U   |
| Aluminium                      | 60 - 90                             | 1469                                      | 2203 | 1364 | 2046 | 1061 | 1591 | 868 | 1302 | 637 | 955 | 382 | 573 | 294 | 441 |
| Brass & Bronze                 | 40 - 50                             | 979                                       | 1224 | 909  | 1137 | 707  | 884  | 579 | 723  | 424 | 530 | 255 | 318 | 196 | 245 |
| Iron:<br>cast(soft)            | 30 - 50                             | 734                                       | 1224 | 682  | 1137 | 530  | 884  | 434 | 723  | 318 | 530 | 191 | 318 | 147 | 245 |
| cast(hard)                     | 15 - 21                             | 367                                       | 514  | 341  | 477  | 265  | 371  | 217 | 304  | 159 | 223 | 95  | 134 | 73  | 103 |
| cast(malleable)                | 15 - 30                             | 367                                       | 734  | 341  | 682  | 265  | 530  | 217 | 434  | 159 | 318 | 95  | 191 | 73  | 147 |
| Steel: mild                    | 24 - 30                             | 588                                       | 734  | 546  | 682  | 424  | 530  | 347 | 434  | 255 | 318 | 153 | 191 | 118 | 147 |
| high tensile                   | 3 - 5                               | 73  | 122  | 68   | 114  | 53   | 88   | 43  | 72   | 32  | 53  | 19  | 32  | 15  | 24  |
| stainless (free cutting)       | 15 - 18                             | 367                                       | 441  | 341  | 409  | 265  | 318  | 217 | 260  | 159 | 191 | 95  | 115 | 73  | 88  |
| stainless (heat resisting)     | 6 - 13                              | 26  | 318  | 136  | 296  | 106  | 230  | 87  | 188  | 64  | 138 | 38  | 83  | 29  | 64  |

These are only starting points. They will vary with application and work piece condition.

| Material or Application Type   | Feed Per Tooth (mm)                                     |
|--|---|
| Thin Walled Workpieces<br>Oblique Entry / Curved Surfaces<br>Semi-Circles / Fragile Setups | .0254 / .0508 (.0762 FPT with Work Hardening Materials) |
| Soft / Gummy Materials   | .1016 / .127  |
| Typical / Average Applications   | .0762 / .1016   |
| Deep Holes   | .1016 / .127  |

Difficult-to-machine materials will require reduced feed rates.

# Rotabroach<sup>TM</sup>

## 19) WARRANTY STATEMENT

Rotabroach<sup>TM</sup> warrants its machines to be free from faulty materials, under normal usage of machines, for a period of 12 months from initial date of purchase. All other parts (excluding cutters) are under warranty for 90 days, provided that the warranty registration card (or online registration) has been completed and returned to Rotabroach<sup>TM</sup> or its designated distributor within a period of (30) days from the purchase date. Failure to do so will void the warranty. If the stated is adhered to, Rotabroach<sup>TM</sup> will repair or replace (at its option) without charge any faulty items returned.

**This Warranty does not cover:**

1. Components that are subject to natural wear and tear caused by the use not in accordance with the operators instructions
2. Defects in the tool caused by non-compliance with the operating instructions, improper use, abnormal environment conditions, inappropriate operating conditions overload or insufficient servicing or maintenance.
3. Defects caused by using accessories, components or spare parts other than original Rotabroach<sup>TM</sup> parts.
4. Tools to which changes or additions have been made.
5. Electrical components are subject to manufacturer's warranty.

Your online registration can be submitted at [www.rotabroach.co.uk](http://www.rotabroach.co.uk)

The warranty claim must be logged within the warranty period. This requires the submission or sending of the **complete** tool in question with the original sales receipt which must indicate the purchase date of the product. A complaint form must also be submitted prior to the return.

This can be found online at [www.rotabroach.co.uk](http://www.rotabroach.co.uk). Failure to complete this form will result in the delay of your claim.

All goods returned defective must be returned pre-paid to Rotabroach<sup>TM</sup>, in no event shall Rotabroach<sup>TM</sup> be liable for subsequent direct, or indirect loss or damage.

THIS WARRANTY IS IN LIEU OF ANY OTHER WARRANTY, (EXPRESSED OR IMPLIED) INCLUDING ANY WARRANTY OF MERCHANTABILITY OR FITNESS FOR A PARTICULAR PURPOSE. ROTABROACH<sup>TM</sup> RESERVE THE RIGHT TO MAKE IMPROVEMENTS AND MODIFICATIONS TO DESIGN WITHOUT PRIOR NOTICE

**Known and Trusted Worldwide for Quality, Performance and Reliability**